

Schwerteilausleser Typ Linus Gravity Separator Type Linus

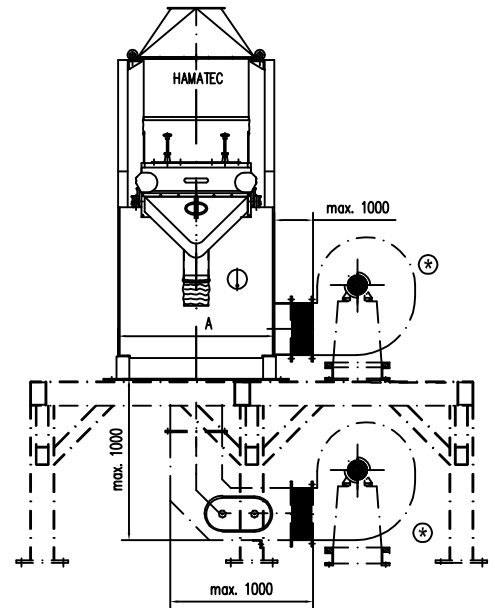
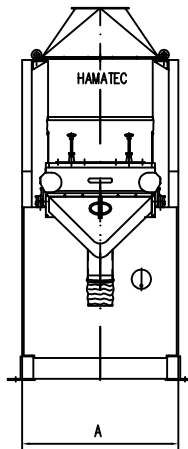
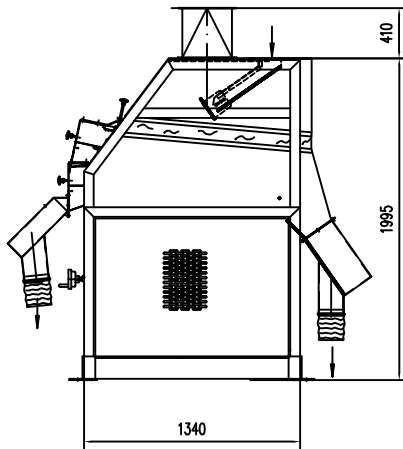

Typ Type Linus	A	Siebgröße sieve size	Ventilator fan kW	Antrieb Drive kW	Abluft Exh. air m³/min	Gewicht weight kg
DG20/12A	970	600/1200	2,2	0,55	82	1050
DK20/12A	970	600/1200	3,0	0,55	110	1065
DG30/12A	1270	900/1200	3,0	0,75	120	1170
DK30/12A	1270	900/1200	5,5	0,75	167	1190

Leistungen sind produktabhängig
capacity dependent on product

⊗ Optionen: Ventilatoraufstellung (ATEX)
⊗ options: ventilator installation (ATEX)

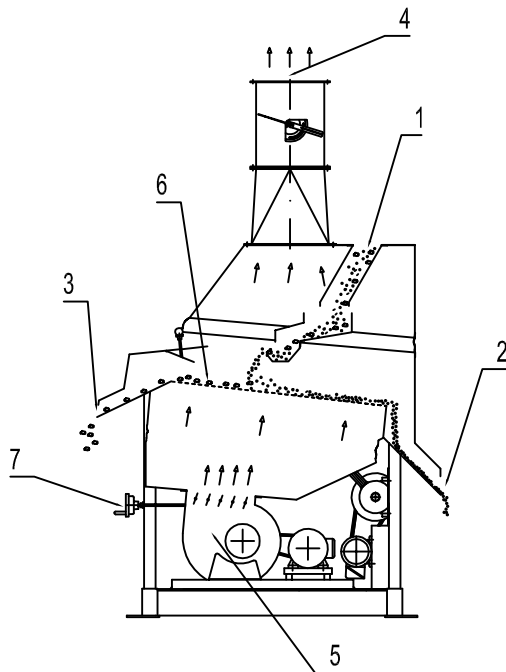

1. Produkt Einlauf
2. Produkt Auslauf
3. Steine-und Schwerteilauslauf
4. Abluft
5. Ventilator
6. Sieb
7. Luftregulierung

1. product inlet
2. product outlet
3. outlet for stones and heavy parts
4. exhaust air
5. ventilator
6. sieve
7. air regulation

- Änderungen vorbehalten -
- subject to alterations -